

ELEMENTS OF GENIUS

NIKKI TESLA
AND THE FELLOWSHIP
OF THE BLING

JESS KEATING
ILLUSTRATED BY LISSY MARLIN



SCHOLASTIC PRESS
NEW YORK

Text copyright © 2020 by Jess Keating
Illustrations by Lissy Marlin, copyright © 2020 Scholastic Inc.

All rights reserved. Published by Scholastic Press, an imprint of Scholastic Inc.,
Publishers since 1920. SCHOLASTIC, SCHOLASTIC PRESS, and associated logos
are trademarks and/or registered trademarks of Scholastic Inc.

The publisher does not have any control over and does not assume
any responsibility for author or third-party websites or their content.

No part of this publication may be reproduced, stored in a retrieval
system, or transmitted in any form or by any means, electronic, mechanical,
photocopying, recording, or otherwise, without written permission of the publisher.

For information regarding permission, write to Scholastic Inc., Attention:
Permissions Department, 557 Broadway, New York, NY 10012.

This book is a work of fiction. Names, characters, places, and incidents are either
the product of the author's imagination or are used fictitiously, and any
resemblance to actual persons, living or dead, business establishments,
events, or locales is entirely coincidental.

Library of Congress Cataloging-in-Publication Data

Names: Keating, Jess, author. | Keating, Jess. Elements of genius; 2.

Title: Nikki Tesla and the fellowship of the bling / Jess Keating.

Description: First edition. | New York: Scholastic Press, 2020. | Series:
Elements of Genius; 2 | Audience: Ages 8–12. | Audience: Grade 4 to 6. |

Summary: When Mary Shelley is kidnapped by a mad scientist, Nikki
Tesla and the other members of the Genius Academy team are forced to
agree to steal a priceless, lethal high-tech ring in order to free her; but

Nikki also plans to use the heist to get closer to her long-lost father
who claims he is not the criminal mastermind she believes him to be.

Identifiers: LCCN 2019025338 (print) | LCCN 2019025339 (ebook) |

ISBN 9781338295252 (hardcover) | ISBN 9781338295276 (ebook)

Subjects: LCSH: Gifted persons—Juvenile fiction. | Private schools—
Juvenile fiction. | Inventions—Juvenile fiction. | Theft—Juvenile
fiction. | Fathers and daughters—Juvenile fiction. | Kidnapping—
Juvenile fiction. | Adventure stories. | CYAC: Genius—Fiction. | Gifted
children—Fiction. | Schools—Fiction. | Inventions—Fiction. |

Stealing—Fiction. | Fathers and daughters—Fiction. | Kidnapping—
Fiction. | Adventure and adventurers—Fiction. | BISAC: JUVENILE
FICTION / Action & Adventure / General | JUVENILE FICTION /
Science & Technology | LCGFT: Action and adventure fiction.

Classification: LCC PZ7.K22485 Nh 2020 (print) | LCC PZ7.K22485
(ebook) | DDC 813.6 [Fic]—dc23

LC record available at <https://lcn.loc.gov/2019025338>

LC ebook record available at <https://lcn.loc.gov/2019025339>

10 9 8 7 6 5 4 3 2 1

20 21 22 23 24

Printed in the U.S.A. 23
First edition, February 2020
Book design by Keirsten Geise

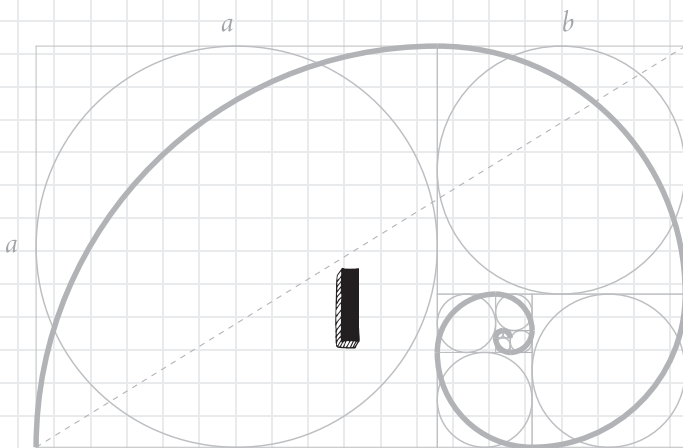

Okay, Tesla. You've got two minutes before your best friend dies. Get it together.

Unfortunately, my ferret wasn't cooperating.

"Pickles, I swear, if you sneak into my lab and pee on my equipment one more time, I'm going to personally build a rocket ship so I can send your little monkey butt to the moon." I dropped a folded paper towel onto the ground and swiped it through the wet puddle with the toe of my shoe. "Ugh!"

Honestly, how was I supposed to save my best friend *and* remain on the forefront of invention if my ferret wouldn't answer nature's call in her litter box like a normal pet?



Pickles answered me by sniffing my foot, rolling onto her back, and nibbling at a newspaper clipping that had fallen from my desk.

“Hold it!” I demanded, reaching down to grab the tattered piece of paper before it got covered in her slobber. “That’s not for you.”

I blew the dust from the bold headline in my hands and set the article in the open drawer to my left with the others I’d pulled from the academy’s archives. “You

shouldn't eat newspaper," I scolded Pickles. "You're going to get a stomachache. Especially from something like this..." I cringed at the chaotic image in the story: Dad's laboratory, blown to pieces.

In response, Pickles lolled onto her belly and began chewing on the nub of my shoelace.

"Yeah, yeah," I said. "Keep on ignoring me. I see how it is." I leaned over and scooped her up, setting her on my desk. I used tweezers to grab one of the clear raised dots from my microscope slide and placed it on the tip of my finger just as my watch began to buzz.

"Shoot," I muttered. I was late. Mary wouldn't be happy.

"You see this?" I asked. Pickles snuffled the dot eagerly, licking her chops and preparing to eat it.

"Hey!" I scolded her. "It's not food." I yanked my hand away. "It's the *future!* Hold still. Remember what we talked about, okay? If this doesn't work, we're putting everyone here at risk. We're all relying on you. You've got to find her."

Pickles continued to watch me, blinking her chocolate brown eyes.

A word of warning to you: If you're ever in a life-or-death situation, don't trust your ferret to save the day.

At least, not until she's better trained.

I pulled her blue collar away from her fur and affixed the dot to it, sticky-side down. “Now go find Mary,” I instructed. “Her life depends on it! Do you hear me?!” I smacked the table to show my urgency. “Go!”

Pickles seemed to understand, because she tore out the room like, well . . . like a ferret in search of food. You haven’t seen speed until you’ve seen that.

I pressed a button on my watch and followed the ticking seconds, growing more nervous by the second. Only two minutes to go before the whole thing was a bust. I tried to distract myself by pacing, but every squeak of my sneakers on the marble floor reminded me of Mary. She was probably sitting on the very same floor right now, waiting for me and my undisciplined ferret to rescue her.

Sorry. Am I getting all life-and-death dramatic too early in the story here? I should probably introduce myself, especially if you haven’t read any of these official government records before.

I’m Nikki Tesla, and there are a few things you should probably know about me before we continue. The first is that I’m a genius. I’m not saying that to impress you. I actually *am* a genius. In fact, I attend Genius Academy, a special school for kids like me with skills that tend to put

us, or those around us, in danger. (They say danger, but I say *fun*, you know?)

My best friends are Mary Shelley (that's who my ferret, Pickles, is trying to save right now), Grace O'Malley, Charlotte Darwin, Adam Mozart, Leo da Vinci, and Bert Einstein. You probably haven't heard of them because Genius Academy is top secret. That's why the government will censor anything I say about where the school is located, what we get up to around here, or anything else they deem inappropriate.

Wanna see?

Genius Academy is located in [REDACTED].

Genius Academy is run by a super smart (but also oddly terrifying) woman named Martha [REDACTED].

The government spends over [REDACTED] million dollars a year on our laboratory spaces, private jets, security, and ice cream truck.

See? I'm not allowed to tell you anything top secret. (For the record, that on-site ice cream truck is spectacular. You have to try the mint chip if you're ever in the area.)

But ever since the super-cool-but-admittedly-fairly-dangerous death ray I invented was stolen last month by a madman who almost used it to destroy the world for

profit, I've decided to keep these records indefinitely. You know, just in case the government decides to blame me for any more destruction of property or global meltdowns. I think of them as insurance.

Sometimes I'll even get Leo to include some pictures for the sake of clarity. He's a pretty great artist, but don't tell him that or he'll be impossible to live with.

Thankfully, the days of risking my life and nearly destroying the world are far behind me. At least for now. That should bring you up to speed.

Oh, time's up.

My watch buzzed and I cursed out loud.

Exactly three seconds later, Mary's resigned voice interrupted my thoughts.

"And she's late," she muttered. "They're going to kill me."

Mary wasn't in the room with me—she was in my ear. Pickles had found her two seconds too late.

But it was working! I scrambled for my notes. "Mary! Mary, can you hear me?"

A brief commotion of rustles and squeaks erupted in my ear. I could envision Mary picking up my ferret and inspecting her. "Nik? Is that you? I can hear you, but where are you?!"